

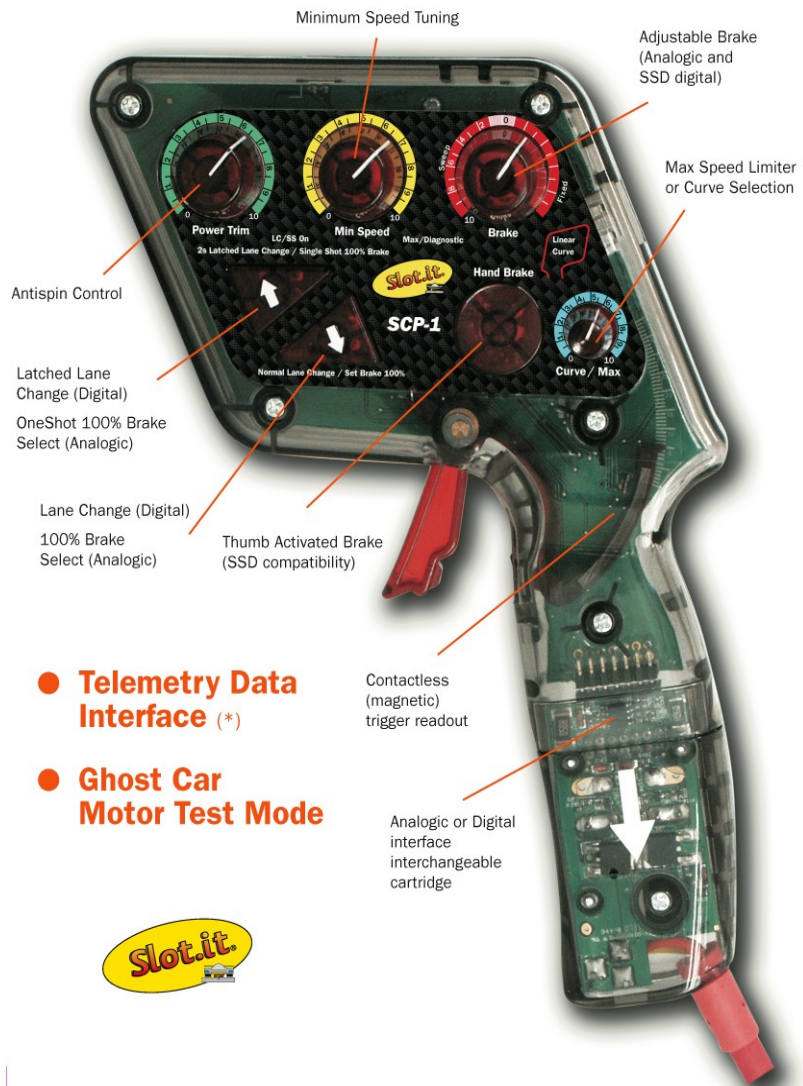

# SCP-1



- Telemetry Data Interface (\*)
- Ghost Car Motor Test Mode

Technical Specifications	
Power supply	9 to 24V
Maximum motor current (peak with analog std cartridge)	6A
Operating temperature	0 to 40°
Weight	270 g

 (UK) Warranty: two years. We reserve the right to refuse warranty repair if safety seal is broken. This device complies with RoHS directive. Do not immerse this controller in water.

No animals have been used for testing this controller, but several slot cars flew off the track in the development phase. The name SCP-1 means SeCaPelo-1 (Secapelo=Hairdryer).

Made in China.

Completely envisioned, thought and designed by Maurizio Ferrari, Maurizio Gibertoni, Cristian Anceschi and Stefano Giorgi of Galileo Engineering srl, Via Cavallotti 16 – 42100 Reggio Emilia, Italy - [www.slot.it](http://www.slot.it) - [info@slot.it](mailto:info@slot.it)

Slot.it and the Slot.it logo are registered trademarks belonging to Galileo Engineering srl.

Slot.it is in no way affiliated with Carrera, Hornby Hobbies, Ninco, Tecnitoy's; Carrera Pro-X, Carrera Digital 132, Hornby SSD, Ninco N-Digital, Tecnitoy's The Digital System SDS, are registered trademarks belonging to their respective owners.

Thank you for purchasing this Slot.it controller. Before starting, please make sure you have read through the following instructions carefully. **The complete printed manual is in English.**

**Electronic versions of the manual in Italian/Castellano/German can be downloaded from the Slot.it site: [www.slot.it](http://www.slot.it)**

The SCP-1 is contactless, friction free, with linear magnetic trigger position readout (patent pending), and features an interchangeable cartridge system, to connect to either analog or digital systems. The digital cartridge is universal for all the available commercial brands (Ninco, Carrera, Hornby and Tecnitoy's). For the Davic system, the list of components and PCB layout for a compatible digital cartridge will be made publicly available.

# Slot.it SCP-1

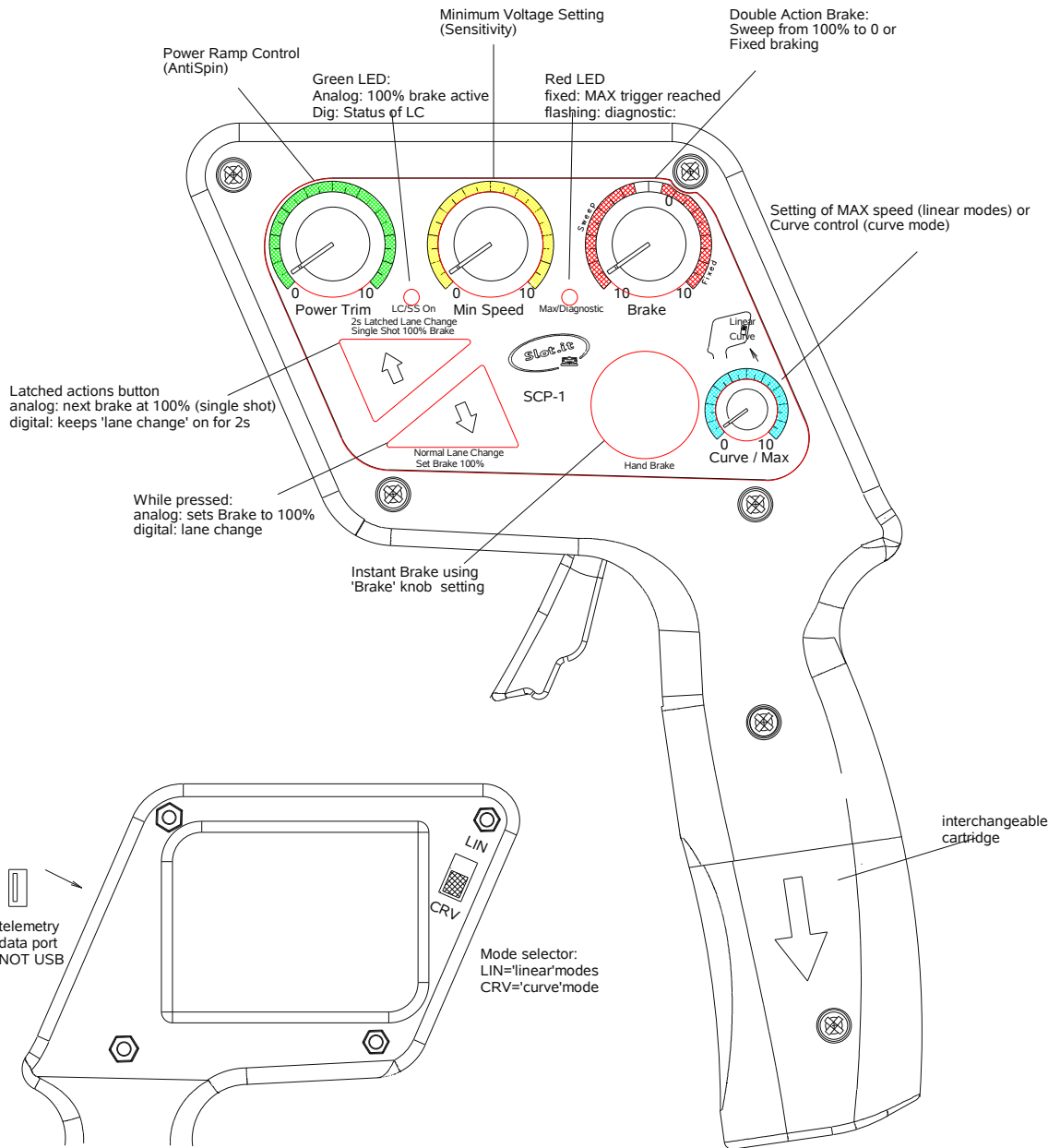
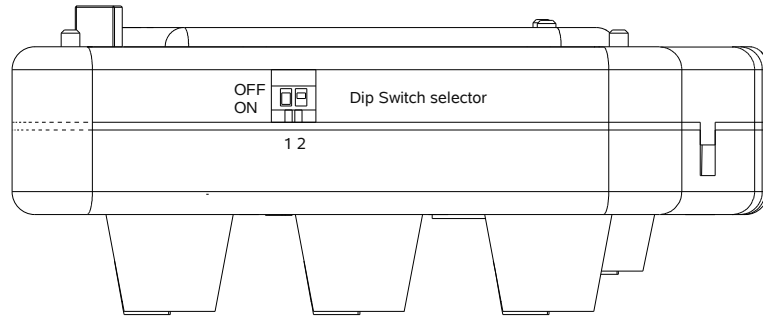

## QUICKSTART for ANALOG SYSTEMS (SCP-1 with analog cartridge)

  The colour scheme of the SCP-1 cables follows the standard US (Parma) colour coding. In

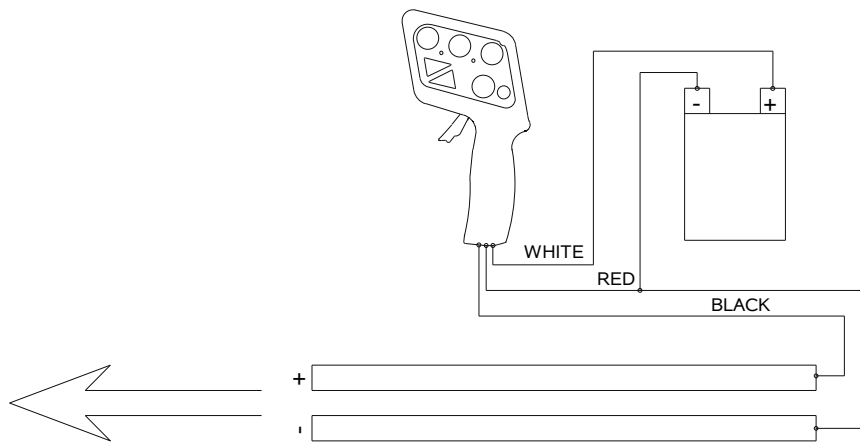

our opinion, it does not make sense to use anything other than red for battery power and anything other than black for ground, however since the long time standard established convention is different, we decided, reluctantly, to follow it.

So: WHITE is +, RED is – (ground), BLACK is motor (track). If you have a DS connection box, colour will match the existing colours on the female plugs of the box.

Anyway: plug the WHITE/YELLOW cable into the POSITIVE (+) terminal of your track; plug the RED cable into the NEGATIVE (-) terminal of your track; plug the BLACK terminal to the motor connector of your track, then go to the **Quickstart common section** chapter.



## QUICKSTART for DIGITAL SYSTEMS (SCP-1 with digital cartridge)

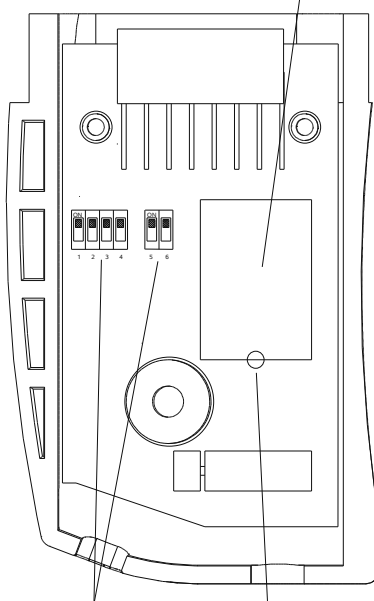



female 8/8 RJ45 connector

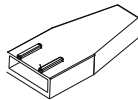
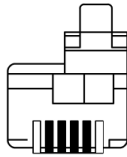
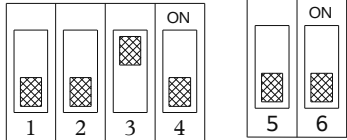
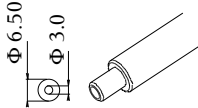

Dip Switch  
1 2 3 4 5 6

through hole

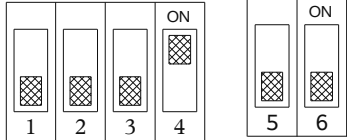
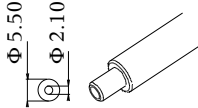
  The Slot.it SCP-1 controller for digital tracks can be used with all available commercial digital systems for plastic tracks: Carrera, Ninco, Hornby and Tecno toys. All these systems are mutually incompatible; the SCP-1 is the first device that is mutually compatible with all of the above. Differently from the controllers supplied by the abovementioned makers, which are sold together with the track, this controller is *active*, that is, it needs its own power supply. Only one of these brands makes its own custom power plug. Anyway, for all these systems we provide 'vampire' cables to bring power from the supply line to the controller. Further, each digital system has got its own different cable plug. The SCP-1 (*digital version only*) includes all the necessary cables to interface it to the control box of your digital system, as well.

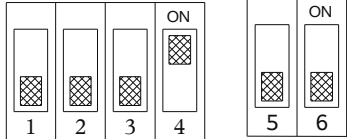
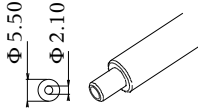
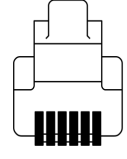
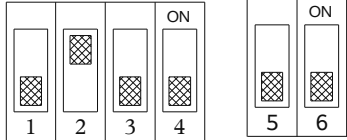
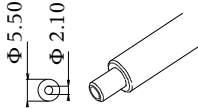
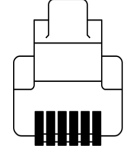
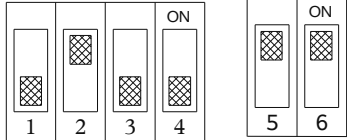
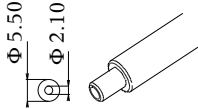
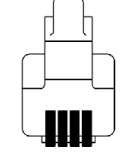
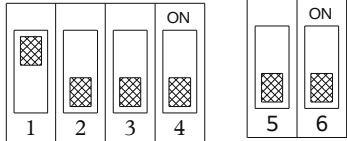
	Power plug	Control plug	Dip switch
Carrera Pro-X and Digital 132	Custom 	MMJ 6/4 	off off on off      off off 
Hornby SSD 4 car base (15V)	6.5/3.0mm round male jack 	jack submin 2.5mm 	off off off on      off off 
Hornby SSD 6 car base (12V)	5.5/2.1mm round male jack 	jack submin 2.5mm 	off off off on      off off 
Tecnoyos SDS (Central unit 2500)	5.5/2.1mm round male jack 	RJ11 6/6 	off on off off      off off 
Tecnoyos SDS (Pit box unit 2506)	5.5/2.1mm round male jack 	RJ11 6/6 	off on off off      on on 
Ninco N-Digital	5.5/2.1mm round male jack 	plug 4/4 	on off off off      off off 

 (UK) Locate the Dip Switch on the controller's cartridge and set it to the position corresponding to the system you have (default from factory: SSD), using the table above as reference. Please note that in the above table, 'x' means 'don't care', i.e. for example for Ninco N-Digital, you must set switch number 1 to '1', and all the rest are ignored. Find the appropriate power cable, and connect it between your track's power supply and control box. Connect the male jack to the SCP-1 controller. Choose the control cable for your system, according to the table, and connect it to the SCP-1 (RJ45 end) and to your control box (side according to the table above). Note that to remove the control cable from the controller, you need to insert a pointed object into the small through hole in the plastic case, located underneath the female connector of the control cable, and press the cable's plastic tab upwards.

Now go to the **Quickstart common section** chapter.

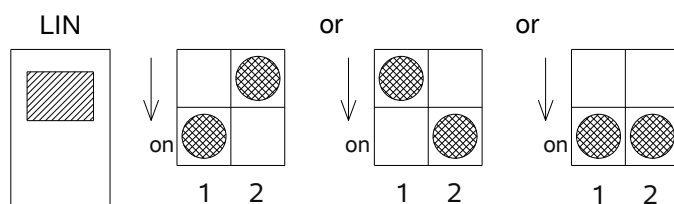

(UK) Move the slider on the back of the controller to the LIN position, and the dip switches to any of the '11' or '10' or '01' position; if the controller is brand new, the standard configuration ('LIN' and '11') is fine.

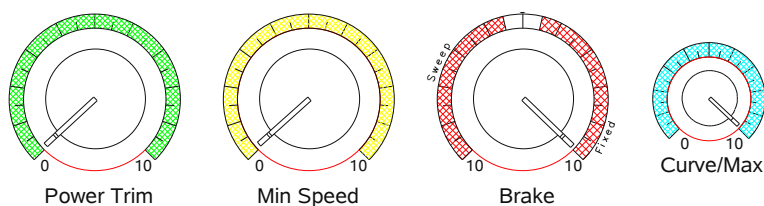

(UK) Turn the 'Power Trim' and 'Min Speed' knobs completely counterclockwise. Turn the 'Brake' and 'Curve/Max' knobs completely clockwise.

Press the trigger and the car should start. Adjust the 'Min Speed' knob to get a good starting speed; this will depend on the track, car, driving style and voltage. Then, adjust the Curve/Max knob to suit the whole curve to the desired response.

Have fun. Then *please*, read the rest of this manual.

(To be sure the rest of this manual is not skipped, we could have inserted here something really scary like 'operating your slot car with this controller without reading the manual first, will result in your *real* car being towed away, a grasshopper's invasion, or an earthquake', to scare you to death so that you would *really* read the rest of this manual. However, it seems more reasonable to say: *please* read the rest of the manual, it is time well spent. After all, this controller cost you some money, and you want to get the most out of it, don't you?)

## Understanding how the SCP-1 works

 (UK) The Slot.it SCP-1 is a sophisticated, microcontroller based, speed controller for slot cars. It has a PWM output for both power and brake, plus a lot of other features.

Without entering too much into detail, PWM (Pulse Width Modulation) is one of the possible ways to control the output voltage of an electronic system. A PWM system basically 'chops' the output voltage in a series of on-off periods, whose on-off ratio corresponds to the desired voltage according to the formula  $V = \text{on-off ratio} * \text{track voltage}$ . In other words, if you have a track voltage of 12V, and an on-off ratio of 1/4, you are feeding your car  $1/4 * 12 = 3V$ , and so on.

The ratio is chosen by the microcontroller, according to the trigger position and to the desired 'response curve'.

The SCP-1 has basically three, very different operating modes, plus a 'ghost' (automatic) mode:

1. **LINEAR with step (mode 1):** the relationship between the trigger and the voltage output is a straight line. The controller, when the trigger is fully pressed, will always provide 100% power. Due to its innovative and in our opinion clever, strategy, this mode has a lot of flexibility and can help in the most difficult situations.
2. **LINEAR with max speed limiter (mode 2):** the relationship between the trigger and the voltage output is a straight line, but when the trigger is fully pressed, optionally, the voltage can be reduced down to a selectable minimum of 60% of the available voltage. This is extremely useful, for example, for children.
3. **CURVE mode (mode 3):** a very sophisticated mode with full control of the response curve, where the relationship between the trigger and the voltage output is not a straight line, but can be made convex or concave more or less at will.

There is also a further useful mode:

4. **GHOST mode (mode 4):** a self-run mode with adjustable speed, useful for running a ghost car on the circuit (or more, if more digital cars are programmed with the same ID), or running in a motor.

### Mode 1 – LINEAR with step - explained

#### Entering Mode 1

Mode 1 is selected by putting the switch on the back of the controller to the 'LIN' (top) position, and the dip switches (DS) on the top side, to any position except the '00' one:

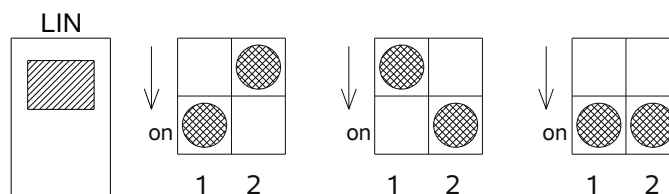

#### Using Mode 1

In the development process of the SCP-1's software, at a certain point we started to investigate why a given car, very easy to drive below a given voltage, was very 'rough' and unpredictable with increasing voltage levels. It was not a matter of excessive speed, the problem lied in the broken link between the finger and the car: somehow, a well-behaved system became increasingly wild and uncontrollable. Every slot car racer knows that, but we needed a physical, logical explanation to this well-known fact.

Come think about it, a basic truth applies: more or less, *the speed of a given car in a given turn is largely independent of the motor power*, that is, provided your motor is powerful enough, and most

motors are powerful enough to de-slot a car in a turn, the speed in a turn depends on many factors but not the power of the motor, or the track voltage. So, what happens when you increase the voltage, and why does it make things so much more difficult?

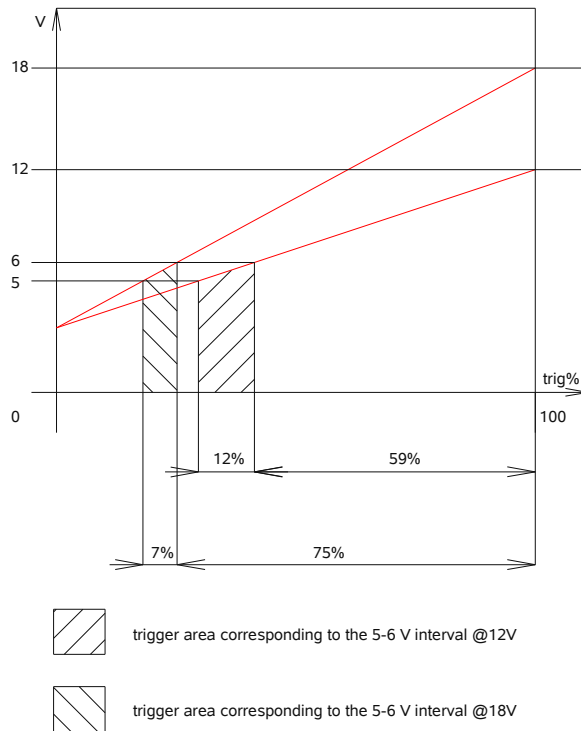

Let's suppose in a given turn the car can be driven optimally in a voltage range between, say, 5 and 6 Volt. In the given example (which is an example only), at 12V this range falls across a 12% band, which, in turn, is located approximately 30% from 0. But look at what happens at 18V: the same 5-6 Volt band is now spread across a 7% band, which is also much closer to the 0 position than before!

So, ideally one would want, in this case, to have a controller, which responded as if the power was 12V in the turns, and 18V in straight lines.

From this observation, the 'linear with step' mode was created to keep the power band under control, without sacrificing top speed.

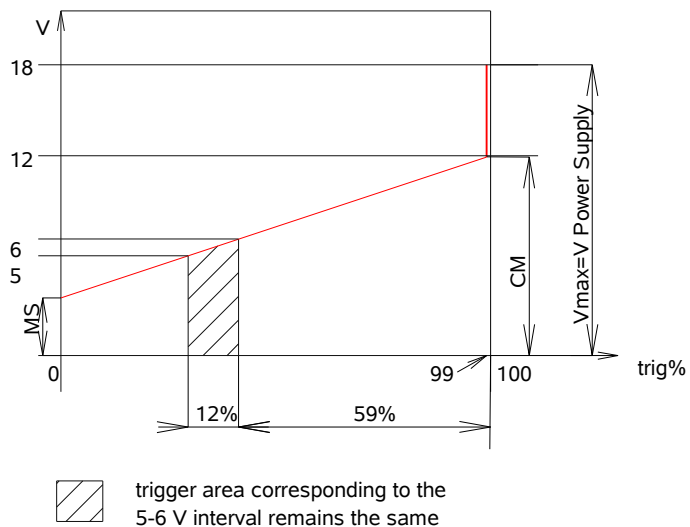



It all works like this: the Min Speed (MS) knob and the Curve/Max (CM) knob set respectively the desired attack voltage, that is, the minimum voltage applied to the motor, and the voltage which is applied when the trigger is at 99% of its run, that is, just before the physical maximum of the trigger's run. When the trigger is pulled 100%, full power (be it 12, 18 or any voltage) is applied. By doing so, it is possible to maintain a fixed, ideal power band for turning, irrespective of track conditions, and to take advantage of the full power on the straights. The transition between the CM value, and the full (100%)  $V_{max}$ , is actuated according to the setting of the Power Trim knob: the more Power Trim is requested, the slower the transition between CM and  $V_{Max}$

It is an easy to tune, very effective strategy.

**Mode 2 – LINEAR with max speed limiter - explained**

**Entering Mode 2**

Select mode 2 by putting the switch on the back of the controller to the 'LIN' (top) position, and the dip switches (DS) on the top side, to the '00' position:

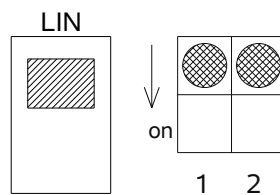

**Using Mode 2**

Mode 2 does everything mode 1 does, but with a very important difference: the maximum voltage is always limited to the value set by the CM knob. This is extremely useful when, for whatever reason, top speed should be reduced, like for example when children are playing with vintage slot cars...

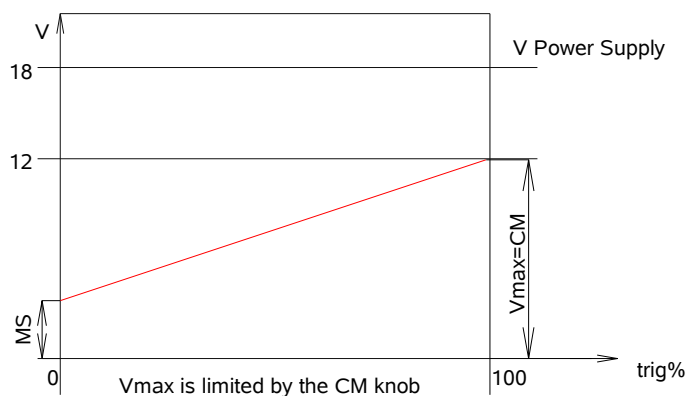

## Mode 3 – CURVE - explained

### Entering Mode 3

Select mode 3 by putting the switch on the back of the controller to the 'CRV' (bottom) position.

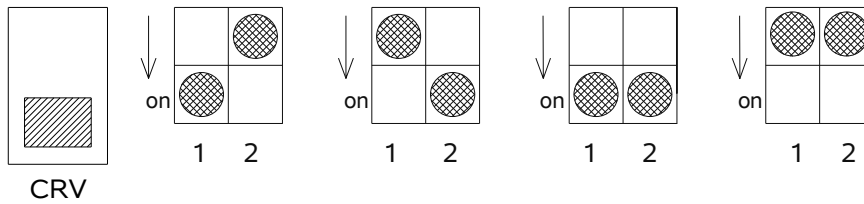

### Using Mode 3

The 'Curve' mode is very flexible. By appropriate adjustment of the Curve/Max CM knob, together with the position of the dip switches (DS), the response curve can be custom tailored.

To understand how it works, consider that the curve of the trigger position/Voltage relationship is built by three points:

1. Min, which is the attack speed set by the MS knob, and varies according to the relative setting.
2. The middle point, which is defined by the position of the dip switches, and by the CM cursor: the switches, according to their setting, draw a horizontal line on the vertical 'voltage' axis at 35% or 45% or 55% or 65% of the maximum power; the CM draws a vertical line on the horizontal trigger axis, and the intersection of these two lines sets the middle point.
3. The Max Voltage, which in this case is always 100%, that is, in the 'curve' mode it is not possible to decrease the maximum power.

In the following example, given a certain MS knob position, and fixed a certain dip switch selection, by turning the CM knob the curve varies as shown below.

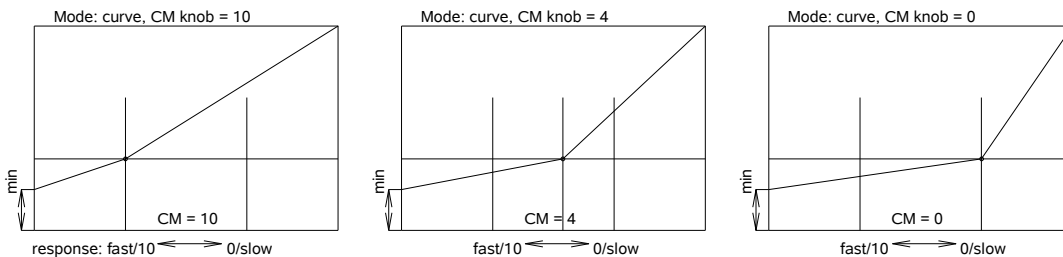

*Example of curves with given MS and DS, CM change*

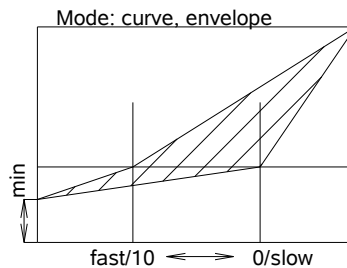

*Envelope of curves with given MS and DS, CM change*

Obviously, the curve can vary continuously between the one represented with CM=10 and the one with CM=0. The middle curve, with CM=4 is an example of an intermediate situation. The envelope of possible curves, with the above said fixed MS and dip switch setting, is explained by the picture right above.

What happens now to our curves, if we change the position of the minimum speed (MS) knob?

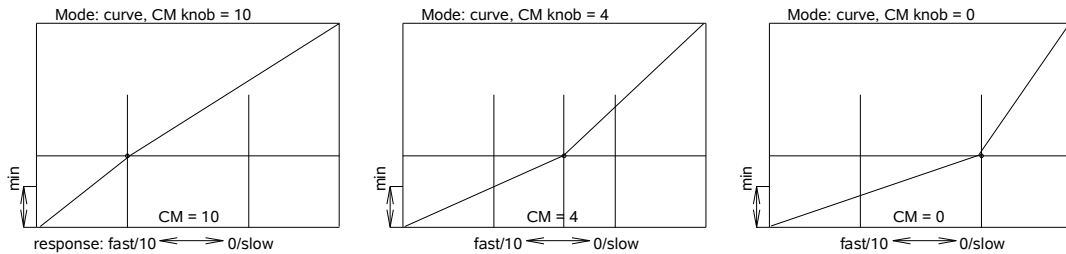

*Example of curves with MS=0, given DS, CM change*

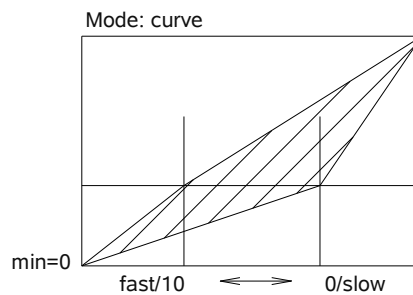

*Envelope of curves with MS=0, given DS, CM change*

At this point, it is easy to visualize the complete envelope of a sample situation, i.e. the complete set of curves that can be obtained with fixed dip switch position, and adjusting CM and MS knobs:

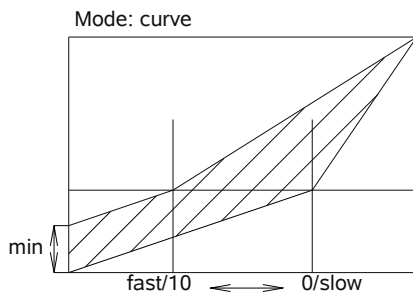

*Envelope of curves with given DS, MS and CM change*

Now let's turn to the meaning of the dip switches, whose purpose is to change the position of the vertical position of the middle point. With reference to the first curve of this chapter, and keeping the CM knob fixed, by changing dip switch we would get the four following different curves:

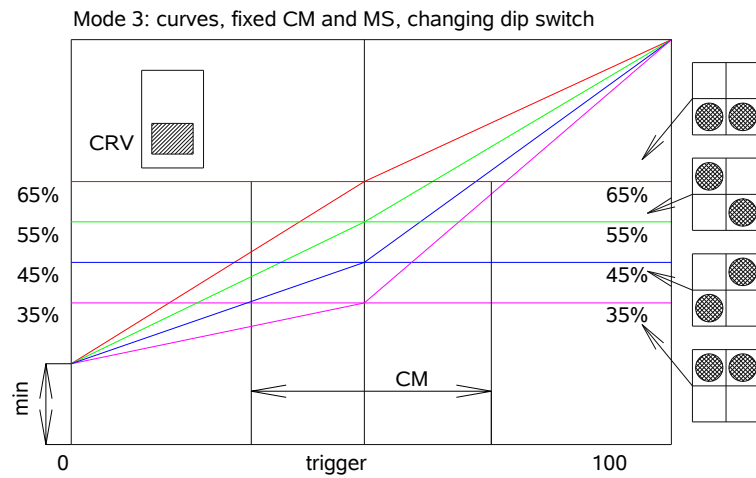

*Example of curves with given MS and CM, changing DS from 00 to 11*

So the complete envelope of curves that can be obtained by changing the MS, CM and DS setting, is as follows.

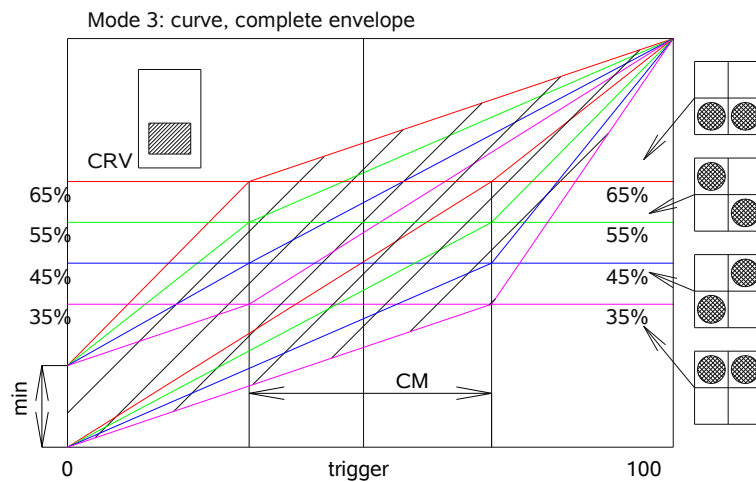

*Envelope of all possible curves*

A spreadsheet is downloadable from <http://www.slot.it> site that shows the changing of the curves for all the possible control settings.

## Mode 4 – GHOST - explained

### Entering Mode 4

Activate the GHOST (auto run) mode by executing the following actions in sequence:

1. turn the Curve/Max knob completely counterclockwise to 0
2. put the CRV/LIN switch on LIN
3. press HAND BRAKE
4. keep HAND BRAKE pressed and press both arrow buttons (LC and Latched LC)
5. pull the trigger to full power
6. completely release the trigger
7. release all the buttons– the LEDs start flashing indicating GHOST mode
8. set speed with CM knob

### Using Mode 4

Speed can be adjusted with the Curve/Max knob. The Hand Brake button, as well as the Lane Change buttons (digital mode), are working.

Exit mode by quickly pulling the trigger to full power and releasing it.

Note that the mode can be entered also skipping step 1. above. The risk in this case is that the speed is adjusted by said knob, so if you leave it to a high setting, as soon as you release the Hand Brake button in step 7, the car will start at warp speed and crash. So, please play safe and turn the CM knob to low before entering mode 4

## SCP-1's controls

The SCP-1 has four main knobs, three push buttons, a sliding switch and two dip switches.

**Power Trim (PT)**: also known as 'antispin', this knob controls how the power trim strategy delivers the power to the car.

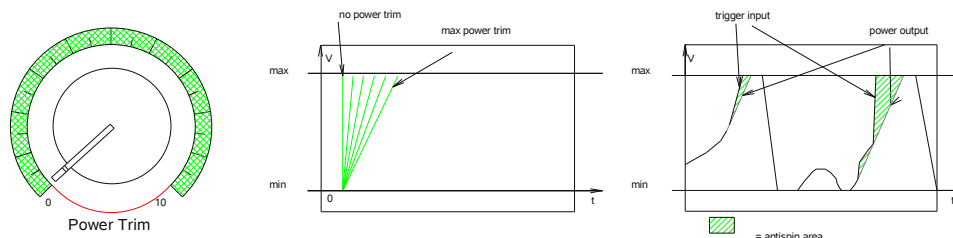

The PT knob sets the maximum accepted 'slope' for a power increase: if the power increase ratio is above this slope, the 'power trim' slope is applied instead. In other words: if the trigger is pulled sharply, the power increase ratio is very high: in this case, the power trim strategy releases the power to the car through a more gentle slope. In reality, a 'real' antispin should monitor the wheel speed and detect wheelspin before cutting back the power. This is not what this controller does, which is, instead, a 'smoothing out' of the trigger action.

Actually, this idea is rooted in what was legal in the F1 rules in the 90s: real closed loop antispin being banned, this was as close as one could legally get.

**PT for digital systems**: there is no difference between the analog and digital controller as far as the PT is concerned.

**Curve/Max (CM)**: the core of SCP-1's inner working. Depending on the chosen working mode, "linear", "linear with speed limit", "curve", it has two completely different functions.

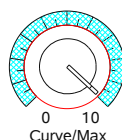

"linear", and "linear with speed limit" modes: if you have *not* read the explanation on these two modes, then now it's probably time to read the relevant chapter. If you have, then this knob sets the maximum speed in both cases.

"curve": if you have *not* read the explanation on this mode, again you should do so now, or proceed at your own risk.... If you have, this knob, in this case, moves the working point on the 'X' axis and, together with the Dip Switch setting, which works on the 'Y' axis, sets the third point through which the curve is set, the other two points being the minimum selected by the MS knob, and the 100% fixed maximum.

**CM for digital systems**: there is no difference between the analog and digital controller as far as the CM is concerned.

**Min Speed (MS):** this knob sets the starting speed of the car, i.e. the minimum voltage which is applied to the track, when the trigger is pulled just enough to leave the 'braking' area. Also known as sensitivity, in terms of a traditional resistor based controller, it is similar to changing the resistor's value, to get a faster or slower start point.

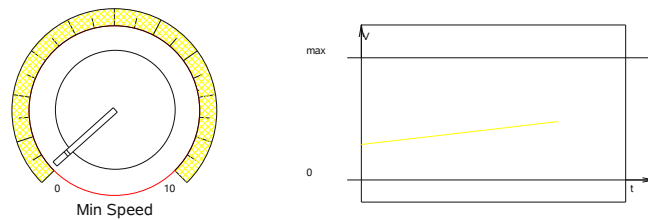

**MS for digital systems:** there is no difference between the analog and digital controller as far as the MS is concerned.

**Braking (BK):** braking occurs when the trigger is completely released. The braking knob selects between two different braking strategies: 'sweep' and 'fixed'. The braking dial is split in two halves: one, under the label 'sweep', puts the braking system in 'sweep' mode, the other half, under the label 'fixed', does the same but for the 'fixed', standard, mode. As this tautology is not probably the best possible explanation, please look at the picture and read on.

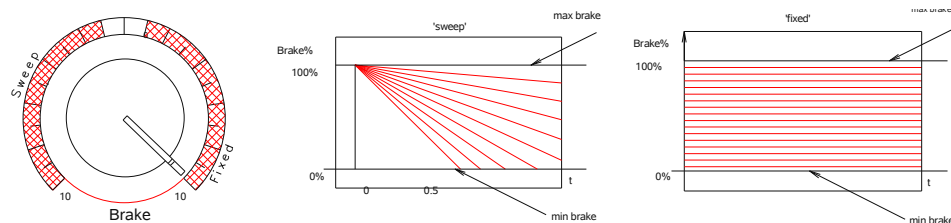

If you have ever been fortunate enough to look at some telemetry data from a real racing car, you might have noticed that the deceleration peaks at the beginning of the braking (in a modern F1 car, deceleration can reach 5g), then decreases as the driver eases the pressure on the pedal, as he tries to match the car's speed to the desired entry speed for the next turn. This is what the 'sweep' braking strategy tries to accomplish: a strong initial braking followed by a gradual easing of the braking itself. In other words: the sweep always begins with 100% braking, then, gradually reduces it to 0 (zero), as time passes. When turned counterclockwise in the 'sweep' area, the knob position controls the sweep time, i.e. how long does it take to bring the braking from 100% to 0. Note that, when fully turned counterclockwise, the braking is fixed at 100%, or, if you like to put it this way, the time it takes to bring the braking to 0 is infinite. Apart from this position, the longest available sweep is 1.7s, and the shortest is 0.5s.

The 'fixed' mode, clockwise, is the 'standard' mode of most, if not all, other controllers with adjustable braking: depending on the dial position, you get a stronger or weaker braking according to the knob setting.

**BK for digital systems:**

Hornby SSD: braking can in fact be adjusted with the BK knob as you would on an analog system. Only, the possible settings are 100%, 80%, 60%, 40%, and 20%.

Ninco N-Digital: either brake 100%, or no brake.

Tecnoyos SDS: no braking is provided by Tecnoyos on their system, so there's no braking available with the SCP-1, either.

Carrera: always 100% brake when available from the track (preliminary).

**Hand brake (analog and digital mode):**

The round push button marked 'Hand Brake' is an instant brake, thumb activated. While pressed, power is cut and braking performed according to the BK knob setting.



**Brake overrides (analog mode):**

There are two ways to change the brake setting on the fly, and temporarily, without altering the base setting selected by the BK knob:

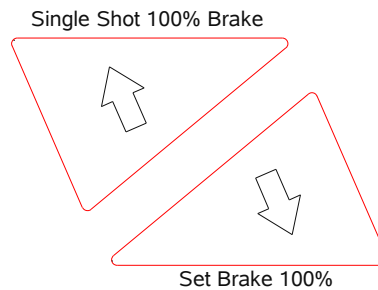

1. the 'UP' arrow button performs a 'single shot' brake override: the next braking action will always occur at 100% braking, regardless of the current BK settings. This can be useful in several situations: for example, in a circuit where 100% braking would not be the best choice, except for a single narrow turn. While active, that is, when the button has been pressed but braking did not take place yet, the green light stays ON. A further pressing of the 'UP' arrow when the strategy is active will switch it off.
2. the 'DOWN' arrow button, while pressed, overrides any braking knob settings, forcing braking at 100%, as long as it is pressed.

**Lane change (digital mode):**

There are two ways to change lane:

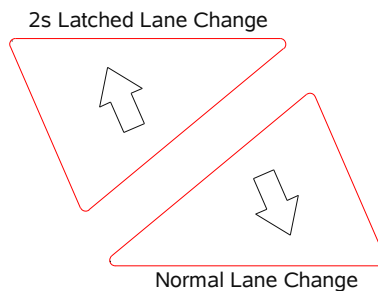

1. the 'UP' arrow button is a 'Latched Lane Change' command: what it means is that once



pressed, for 2 seconds it keeps the Lane Change command active, like if the driver was keeping the Lane Change command pressed himself. The advantage of this is that, once pressed, the driver can concentrate on driving, and the SCP-1 will take care of lane changing, for the next two seconds. A further pressing of the 'UP' arrow when the strategy is active will switch it off.

- the 'DOWN' arrow button, while pressed, activates the Lane Change mechanism.

**CRV/LIN selector and DIP Switches (top of controller):**

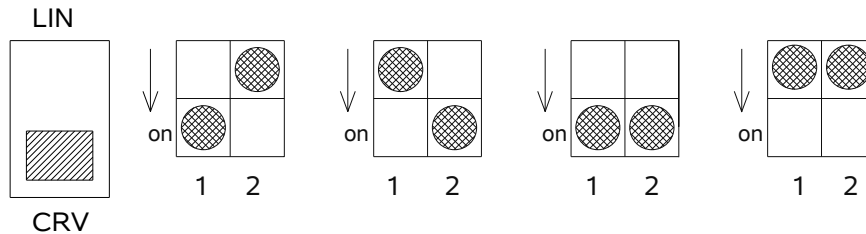

The CRV/LIN selector and the Dip Switches are located respectively on the back and on the top of the controller. Together, they are used to select the working modalities of the SCP-1.

**DIP Switches (digital cartridge only):**

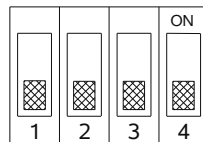

The DIP Switches located on the controller's digital cartridge are used for selection between the different digital systems. Please refer to the Quickstart for Digital chapter for a thorough explanation

**Telemetry interface:**

**The USB-like data port on the side of the controller is NOT a USB PORT. Do NOT connect it to your PC or data key.** It does not harm the SCP-1 or the PC, but is completely useless to do so.

The SCP-1 provides a data port for telemetry transmission to either a PC, or a USB key. However, to do so, an optional interface box (which will be piggyback mounted on the controller itself) must be used.

Telemetry system handles all driving data (throttle, brake, knobs, etc), shows them graphically in real time on PC screen, and stores it for future retrieval. It's a very handy system to compare car setup, driver's skills, or simply to keep track of your races.

Lap time and sector times are recorded in telemetry as well, but all timing functions need an optional track interface box.

This topic is fully covered in the manuals of the interface box and software.

## How does the SCP-1 protect itself...

As the SCP-1 can operate in a very harsh environment, it has several ways of protecting itself against short circuits and polarity inversions. The following applies to analog systems only.

### ***Protection against short circuit between rails:***

This is the most common situation in normal use. A screwdriver on the track, a screw across the slot, a copper filament crossing the braids are normal events that any controller should handle gracefully. The power MOSFETS used in the SCP-1 are well dimensioned, but this alone is not enough to guarantee a happy and healthy life to your controller. So, the Slot.it SCP-1 continuously monitors the current drain from the track and cuts power if the current is higher than 6A. The situation is checked every few tenths of a millisecond, and if the short circuit goes away, power is restored.

The 'diagnostic' LED flashes with one flash every two seconds while this condition is detected.

This obviously means that with the 'standard' analog cartridge, motors with a very large current drain cannot be used. This excludes the motors commonly used for 'metal slot racing' but includes all motors commonly used in plastic cars. An 'unlimited' cartridge, is planned, for higher current requirements.

In the table below, this protection is referred as SC.

### ***Protection against short circuit to Ground:***

This is quite unlikely during normal use, but can be caused by a mismatch between Motor and Ground cables.

The 'diagnostic' LED flashes with two flashes every two seconds, while this condition is detected.

In the table below, this protection is referred as SC.

### ***Protections against polarity errors:***

The SCP-1 has three cables: **Motor** (Black), **Ground** (Red), **Power** (White).

Two devices protect the SCP-1 against polarity inversion, which happens if the cables are mismatched. This should not happen often, but it *can* happen, so the SCP-1 is shielded by

1. Fast Fuse, 3.15A, replaceable. In the table below, this protection is referred as FF
2. Resettable Fuse (Automatic). In the table below, this protection is referred as RF

Track connectors	SCP-1 connectors					
Motor	Motor	Motor	Ground	Ground	Power	Power
Ground	Ground	Power	Power	Motor	Ground	Motor
Power	Power	Ground	Motor	Power	Motor	Ground
Effect →	OK	FF	RF	FF or SC	RF or SC	FF or SC

### ***What to do:***

If the diagnostic LED flashes once every two seconds, unplug the controller, search and remove the offending item that is shorting the rails. Check that your motor is not draining too much current.

If the diagnostic LED flashes twice every two seconds, unplug the controller, and check your connections.

If you believe there might have been a condition like the ones above, check the Fast Fuse and in case, replace it. The automatic Resettable Fuse resets automatically in approximately 2”.

### ... and how does the SCP-1 protect your chassis

With most (all, that we know of) other electronic controllers, when the power is removed from the track, at the end of a heat, the car suddenly loses any type of braking. This means that if, for example, power is cut when you are full throttle just before a hard braking hairpin, the car will take off and potentially damage itself. We have seen it happen, it can happen.

So, the SCP-1 analog cartridge, sensing that the power is cut, activates the braking system for approximately one second before switching itself off, enough to bring your car to a safe stop.

In all cartridges sold after May, 2008, a dip switch provides a way to select whether the braking action on power loss must be on or off, to get the extra meter of track between heat. Default is no brake when the cap is on the pins.

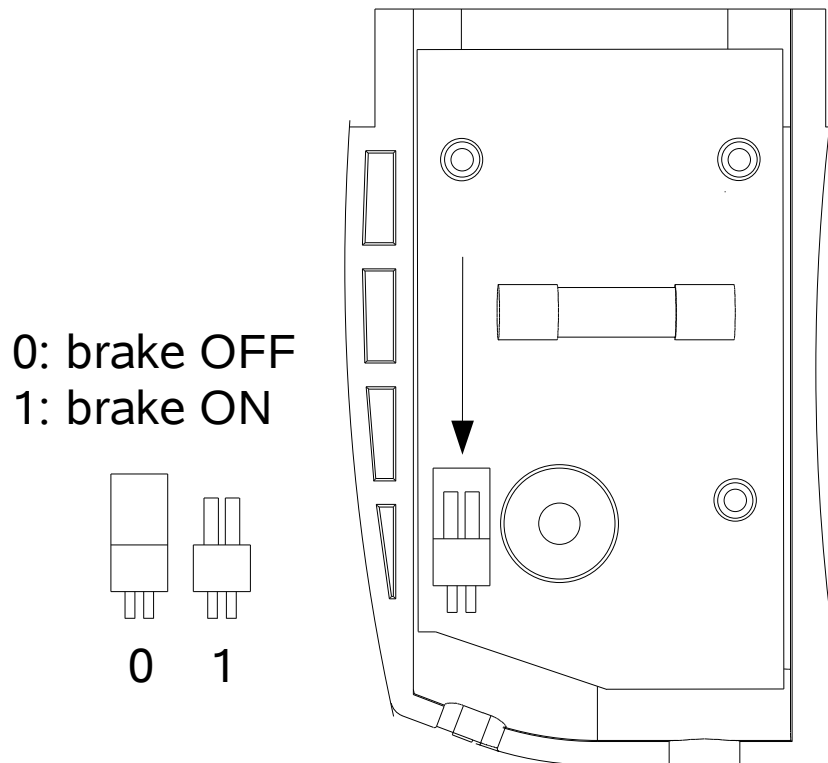

In the digital world, being everything under the control of the base control unit, you are left at its mercy.

### a word about the trigger readout

The SCP-1 reads the trigger position from a magnet housed in the trigger itself. The magnetic field is read by a Hall sensor, whose output is fed to the microcontroller (the CPU). The readout is linear, and there's a patent pending on a couple of technical aspects of this matter. What makes it interesting for the user though, is that, being there no end of run switches or mechanical contacts, there is no friction between the trigger and the cursor as in a traditional controller, which means no wearout, no dust, no change in characteristics.

The SCP-1 comprises a sophisticated software which can detect the end-of-run positions and self calibrate during normal operation. It comes precalibrated from factory so that it works as expected as soon as it is powered up.

However, there is the possibility that, due to violent shock (falls, etc), or component specification drift over time, the base parameters of the magnetic readout system (Hall sensor/magnet) are altered beyond the optimal operating range. Should this happen, the SCP-1 will keep working regularly (unless broken) but, if powered up with the trigger not in the full throttle position, when the trigger is pulled to full throttle for the first time, it might not give full power, or give full power too early.

In this case, the recovery software allows anyway proper working of the SCP-1, but this condition can be rectified by the user him/herself. Please contact the Slot.it assistance in the unlikely event that, after plugging the SCP-1 with the trigger completely released, the red 'max' LED does not light up the first time the trigger is fully pulled, or if you notice a marked difference between the first and second full throttle runs.

**if everything else fails...**

press the large, friendly orange button:



...and contact us at the address in the following page



Galileo Engineering srl, Via Cavallotti 16 – 42100 Reggio Emilia, Italy  
[www.slot.it](http://www.slot.it) - [info@slot.it](mailto:info@slot.it)